

INTRODUCTION

With correct maintenance and proper use, the Gehl 1640E and Mustang 2012 skid-steer loaders will give years of dependable service. This service manual is intended to be a guide in the assembly and disassembly, installation and removal, adjustment and testing, troubleshooting and replacement of components that together make up the Gehl 1640E and Mustang 2012 skid-steer loaders.

In many of the procedures found within, the installation steps are the exact opposite of the removal steps and vice versa, and therefore, the opposite procedure is not written. Instead, a note to reverse the procedure will be stated. This reduces redundancy and excessive pages in the manual. In cases though, where the assembly and disassembly or removal and installation procedures differ and additional steps or safety concerns are paramount, the entire reverse procedure will be written out to include the new information.

The Table of Contents and Index can be used to make the procedure you need to find an easier process. Many schematics, photographs, and line art drawings are used to help perform the necessary repairs, tests, or adjustments that the skid-steer loader needs to keep it in good running condition.

If you have any additional questions, please contact your authorized Gehl or Mustang dealer or call the Gehl Service Department for assistance.

TABLE OF CONTENTS

Specifications	Page
SPECIFICATIONS.....	1

Safety	Page
General Information.....	3
Signal Words.....	3
Additional Safety Reminders.....	3
Mandatory Safety Shutdown Procedure.....	4
Lift Arm Support Device.....	5
Lift Arm Support Device Engagement.....	5
Lift Arm Support Device Disengagement.....	5
ROPS – Raising.....	6
ROPS – Lowering.....	7
Relieving Hydraulic Pressure.....	8
Loader Raising Procedure.....	8
Loader Lowering Procedure.....	8

Lubrication	Page
General Information.....	9
Hydraulic Oil Reservoir.....	9
Crankcase Oil.....	10
Chaincases.....	11
Grease Fitting Locations.....	12
Cooling System Drain Procedure.....	13

Mainframe	Page
Introduction.....	15
Mainframe (Chassis), Rear Grille and Engine Cover Components.....	15
Engine Access Cover - Removal and Installation.....	16
Roll-Over and Falling Object Protective Structure Components - ROPS/FOPS.....	17
ROPS/FOPS Removal and Installation.....	18
Seat Removal and Installation.....	19
Seat Slide Replacement.....	20
ROPS/FOPS Rear Window Removal and Installation.....	20
Restraint Bar Components.....	22

All-Tach® Hitch Components	23
Restraint Bar Removal and Installation	24
All-Tach® Hitch Removal and Installation	25
Lift Arm Removal and Installation	25
Lift Arm Components	26
Lift Arm Bushing Replacement	29
Lift Arm Stop Installation and Adjustment	29
Floor Cover/Step Cover/Kickplate Removal and Installation	30
Crossmember Removal and Installation	31
Fuel Sensor Removal and Installation	32
Rear Grille Removal and Installation	33
Rear Grille Latch Removal and Installation	33

Wheel Drives

Page

Introduction	35
Wheel Drive Components	35
Drive Chain Adjustment	36
Axle Housing Assembly Removal and Installation	37
Drive Chain Removal and Installation	39
Axle and Wheel Bearing Disassembly and Assembly	40

Controls

Page

Introduction	43
Control Locations - T-Bar	43
Wheel Drive, Foot Throttle and Lift Tilt Components - Illustration - Later Models	44
Wheel Drive, Foot Throttle and Lift Tilt Components - Parts Listing - Later Models	45
Wheel Drive, Foot Throttle and Lift Tilt Components - Illustration - Earlier Models	46
Wheel Drive, Foot Throttle and Lift Tilt Components - Parts Listing - Earlier Models	47
Control Handle Removal and Installation	48
Control Handle Position Adjustment	49
T-Bar Control Handle Assembly	50
Backup Alarm Components	51
Pivot Tube Removal and Installation	52
Pump Control Arm Assembly Removal and Installation	53
Lift/Tilt Controls Removal and Installation	53
Lift/Tilt Control Adjustment	54
Auxiliary Hydraulics Cable Removal and Installation	55
Auxiliary Hydraulics Cable Adjustment	57
Engine and Hand Throttle Components	58
Hand Throttle, Foot Throttle Pedal and Throttle Cables/Throttle Rod Removal and Installation	59
Hand Throttle Tension Adjustment	61
Foot Throttle Adjustment	61

Hydrostatic System	Page
Introduction	63
Hydrostatic Components - Standard Drive Motor	63
Hydrostatic Components - Drive Motor with Brake Release Valve	63
Hydrostatic Components	64
Charge Pressure Test and Adjustment	65
Hydrostatic Pump Relief Valves	66
Hydrostatic Pump Removal / Installation.	66
Hydrostatic Pump Drive Coupling Removal and Installation	68
Drive Motor Removal and Installation	69
Troubleshooting Guide	71
Hydrostatic/Hydraulic Schematic.	76, 77

Hydraulic System	Page
Introduction.	79
Hydraulics - Non-Self Level and Self Level Valve Components.	79
Hydraulics - Lift Arm Components	80
Hydraulics - Chassis Components	81
Pressure Tests, Control Valve.	82
Tilt Cylinder Test	83
Self-Leveling Valve Test	85
Lift Cylinder Test	85
Solenoid Valve Test - Tilt, Lift, Brake.	86
Hydraulic Oil Filter Element Replacement	87
Tilt Cylinder Removal and Installation	88
Lift Cylinder Removal and Installation	90
Lift Cylinder Components	91
Tilt Cylinder Components	91
Lift/Tilt Cylinder Disassembly / Assembly	92
Gear Pump Removal and Installation.	94
Self-Leveling Valve Removal and Installation.	95
Self-Leveling Valve Adjustment	96
Safety Lock Valves - Removal/Installation	97
Lift, Tilt and Brake Solenoid Valves - Disassembly and Assembly	98
Control Valve Removal and Installation	99
Main Control Valve Components.	102
Control Valve Disassembly and Assembly	103
Main Relief Valve Removal and Installation	104
Control Valve Spool Seal Replacement	104

Electrical System	Page
Introduction	109
Description of Operation - Right and Left Instrument Panels	109
Electrical Chassis Components	113
Electrical Battery Disconnect Switch Components (EU)	114
Electrical Battery Disconnect Switch Components (Standard)	114
Electrical ROPS/FOPS Components	115
Relay Test and Operation	116
Relay Test - Fuel Pull, Starter, Safety Lock and Auxiliary Neutral	116
Glow Solenoid Test	117
Seat Switch Removal and Installation	117
Restraint Bar Switch Removal and Installation	118
Engine Disconnect Switch - Remote Battery Terminal Removal and Installation	118
Restraint Bar Components	119
Front and Rear Work Light Bulb Replacement	120
Electrical Lights Components	121
Dome Light Bulb Replacement	122
Lift and Tilt Solenoid Test and Operation	123
Brake Solenoid Test and Operation	123
Auxiliary Neutral Start Switch	123
Electrical Schematic	124, 125

Engine	Page
Introduction	127
Troubleshooting Guide	127
Engine Components and Engine Controls	129
Air Cleaner and Exhaust Components	130
Radiator/Cooler Components	131
Oil Filter Element Removal and Installation	132
Air Cleaner Assembly Removal and Installation	133
Air Filter Element Removal and Installation	134
Battery and Battery Tray Removal and Installation	135
Starter Removal and Installation	136
Exhaust Assembly Removal and Installation	137
Fan Belt Adjustment	137
Radiator/ Oil Cooler Removal and Installation	138
Fan Shroud and Support Brackets Removal and Installation	140
Fan Shroud Adjustment	141
Fan Removal and Installation	141
Engine Removal and Installation	142

SPECIFICATIONS

Model	1640E / 2012
Engine Make	Yanmar
Engine Model	3TNV82A-BPMS
Fuel	Diesel
Displacement	81.2 CID (1,33 L)
Horsepower - Net	23.9 hp (17,8 kW)
Peak Torque	68 lbf-ft. (86 N•m)
Rated Operating Capacity	850 lbs. (386 kg)
Operating Weight	2980 lbs. (1352 kg)
Shipping Weight	2820 lbs. (1279 kg)
Capacities	Capacities
Engine Oil	5.8 US qts. (5,5 L)
Fuel Tank	7.7 US gal. (29,1 L)
Chaincase (each)	6.0 US qts. (5,7 L)
Hydraulic Reservoir	7.2 US gal. (27,2 L)
Engine Coolant	8.0 US qts. (7,57 L)
Electrical System	Electrical
Battery	12-V DC, Group 24, 675 CCA, 115 Reserve
Starter	12-V DC (1,7 kW)
Alternator	40 A
Hydraulic System	Hydraulic System
Hydraulic System Pressures	2255 PSI (156 bar)
Standard Auxiliary Flow Rate	10.1 gal/min (38,2 L/min)
Travel Speed (with standard tire)	0 to 5.5 mph (0 to 9,0 km/h)
Tire Options	Tire Options Description
5.70 x 12 Heavy-Duty 4-Ply	NHS Trac Loader Chevron
23 x 8.50-12 Heavy-Duty 6-Ply	NHS Heavy-Duty 2000
Buckets and Capacities	
Width - Description	Capacity (Heaped)
36 inches (914 mm) - Dirt/Construction	5.3 cubic feet ; 0,15 cubic meters
44 inches (1118 mm) - Dirt/Construction	7.4 cubic feet ; 0,21 cubic meters
48 inches (1219 mm) - Utility/Snow	9.8 cubic feet ; 0,28 cubic meters
15.75-19.68-24 inches (400-500-610 mm) Pallet	Not Applicable

*Operating capacity rated with a 5.70 tires, 5.3 cubic foot (0.15 m³) dirt/construction bucket in accordance with SAE J818, SAE J732 and ISO 14397-1.

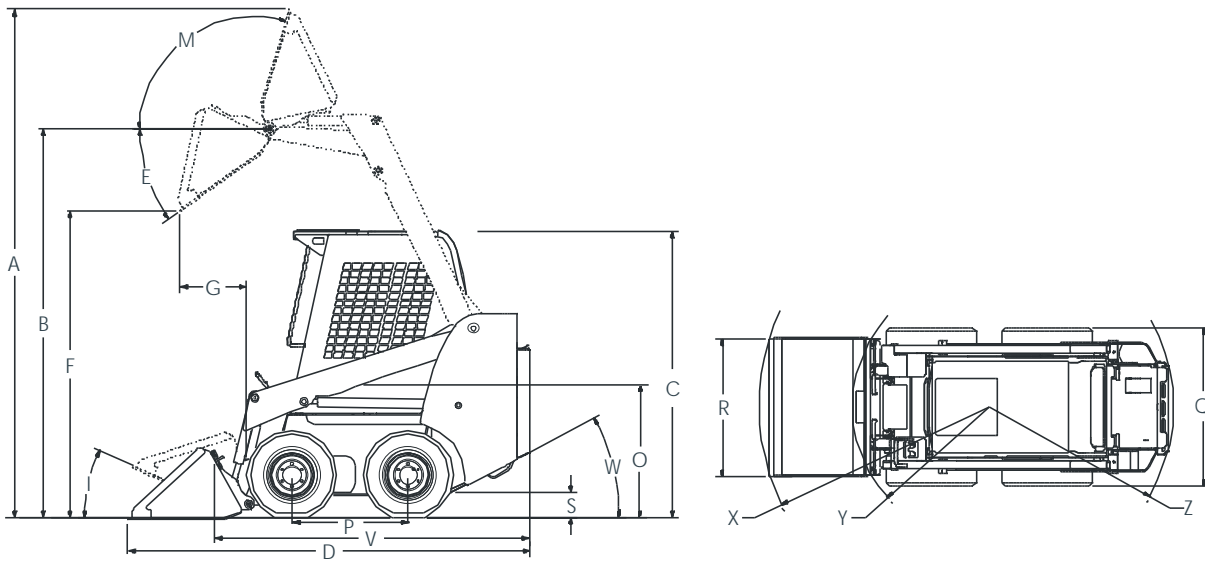

Dimensional Specifications		1640E and 2012 ¹	
		in.	mm
A	Overall operation height - fully raised	124.7	3167
B	Height to hinge pin - fully raised	96	2438
C	Overall height - top of ROPS	74.7	1897
D	Overall length - bucket down	101.4	2576
E	Dump angle @ full height	45.9°	
F	Dump height	72.3	1836
G	Dump reach - bucket (full height)	14.8	376
I	Rollback at ground	23.4°	
M	Rollback angle @ full height	100.3°	
O	Seat-to-ground height	34.6	879
P	Wheelbase - nominal	30.5	775
Q	Overall width - less bucket	35.8	909
R	Overall bucket width	36.0/44.0	914/1118
S	Ground clearance to chassis (between wheels)	6.0	152
V	Overall length (less bucket)	75	1905
W	Departure angle	30.1°	
X	Clearance circle - front (with bucket)	58	1473
Y	Clearance circle - front (less bucket)	32.8	833
Z	Clearance circle - rear	43.2	1097

1 - w/5.3 cu.-ft. bkt./7.4 cu.-ft. bkt., and 5.7 x 12 tires