

[Click here to get the complete manual](#)

# INTRODUCTION

With correct maintenance and proper use, Gehl skid-steer loaders will give years of dependable service. This service manual is intended to be a guide in the assembly and disassembly, installation and removal, adjustment and testing, troubleshooting and replacement of components that together make up the Gehl 40 Series family of skid-steer loaders.

In many of the procedures found within, the installation steps are the exact opposite of the removal steps and vice versa, and therefore, the opposite procedure is not written. Instead, a note to reverse the procedure will be stated. This reduces redundancy and excessive pages in the manual. In cases though, where the assembly and disassembly or removal and installation procedures differ and additional steps or safety concerns are paramount, the entire reverse procedure will be written out to include the new information.

The Table of Contents and Index can be used to make the procedure you need to find an easier process. Also, there are black tabs extending off the pages highlighting the chapters for those who prefer to thumb through the manual. Many schematics, photographs, and line art drawings are used to help perform the necessary repairs, tests, or adjustments that the 40 Series skid-steer loaders need to keep them in good running condition.

If you have any additional questions, please contact your authorized Gehl dealer or call the Gehl Service Department for assistance.

## TABLE OF CONTENTS

<b>Specifications</b>	<b>Page 1-1</b>
Specifications . . . . .	1-1
Tire Options . . . . .	1-1
Buckets and Capacities . . . . .	1-1
Dimensional Specifications . . . . .	1-2
<b>Safety</b>	<b>Page 2-1</b>
General Information . . . . .	2-1
Signal Words . . . . .	2-1
Additional Safety Reminders . . . . .	2-1
Mandatory Safety Shutdown Procedure . . . . .	2-2
Liftarm Support Device . . . . .	2-3
Liftarm Support Device Engagement . . . . .	2-3
Liftarm Support Device Disengagement . . . . .	2-4
Rollover Protective Structure (ROPS) - Raising . . . . .	2-4
Rollover Protective Structure (ROPS) - Lowering . . . . .	2-5
Relieving Hydraulic Pressure . . . . .	2-6
Loader Raising Procedure . . . . .	2-7
Loader Lowering Procedure . . . . .	2-7
<b>Lubrication</b>	<b>Page 3-1</b>
General Information . . . . .	3-1
Hydraulic Oil Reservoir . . . . .	3-2
Crankcase Oil . . . . .	3-2
Chaincases . . . . .	3-3
Grease Fitting Locations . . . . .	3-3
Cooling System Drain Procedures . . . . .	3-4
<b>Mainframe</b>	<b>Page 4-1</b>
Introduction . . . . .	4-1
Engine Access Covers - Removal and Installation . . . . .	4-2
Rollover Protective Structure (ROPS) Removal and Installation . . . . .	4-6
Seat Removal and Installation . . . . .	4-7
Seat Slide Replacement . . . . .	4-7
Air Duct Removal and Installation . . . . .	4-8
Air Duct Louver Replacement . . . . .	4-8

Rollover Protective Structure (ROPS) Rear Window Removal and Installation . . . . . 4-9

Restraint Bar Removal and Installation . . . . . 4-11

Gehl All-Tach™, Power-A-Tach™ Hitch Removal and Installation . . . . . 4-15

Liftarm Removal and Installation . . . . . 4-16

Liftarm Bushing Replacement . . . . . 4-19

Liftarm Stop Installation and Adjustment . . . . . 4-20

Control Cover, Floor Cover Removal and Installation . . . . . 4-20

Crossmember Removal and Installation . . . . . 4-21

Fuel Sensor Removal and Installation . . . . . 4-23

Rear Grille Removal and Installation . . . . . 4-24

Rear Grille Latch Removal and Installation . . . . . 4-24

**Wheel Drives**

**Page 5-1**

Introduction . . . . . 5-1

Drive Chain Adjustment . . . . . 5-2

Axle Housing Assembly Removal and Installation . . . . . 5-3

Drive Chain Removal and Installation . . . . . 5-4

Axle and Wheel Bearing Disassembly and Assembly . . . . . 5-6

**Controls**

**Page 6-1**

Introduction . . . . . 6-1

Control Handle Removal and Installation . . . . . 6-6

Control Handle Position Adjustment . . . . . 6-7

Control Handle Tracking Adjustment, Drive Controls . . . . . 6-8

T-Bar Control Handle Assembly . . . . . 6-9

Hand/Foot Control Handle Assembly . . . . . 6-11

Dual Hand Control Handle Assembly . . . . . 6-12

Pivot Tube Removal and Installation - T-Bar, Hand/Foot and Dual Hand . . . . . 6-16

Neutral Centering Device Adjustment . . . . . 6-18

Control Arm Assembly Removal and Installation . . . . . 6-19

Lift/Tilt Control Removal and Installation . . . . . 6-20

Lift/Tilt Control Adjustment . . . . . 6-23

Auxiliary Hydraulics Cable Removal and Installation - T-Bar and Dual Hand . . . . . 6-27

Auxiliary Hydraulics Cable Adjustment - T-Bar and Dual Hand . . . . . 6-28

Auxiliary Hydraulics Cable Removal and Installation - Hand/foot . . . . . 6-29

Auxiliary Hydraulics Cable Adjustment - Hand/foot . . . . . 6-30

Hand Throttle, Rod and Cable Removal and Installation - T-Bar and Dual Hand . . . . . 6-33

Foot Throttle Removal and Installation - T-Bar and Dual Hand . . . . . 6-34

Hand Throttle Tension Adjustment . . . . . 6-35

All-Tach is a trademark of the Gehl Company.

Hand Throttle and Throttle Cable Removal and Installation - Hand/Foot . . . . .	6-36
Hand Throttle Adjustment - Hand/foot . . . . .	6-37
Foot Throttle Adjustment - T-Bar and Dual Hand . . . . .	6-38

## Hydrostatic System

Page 7-1

Introduction . . . . .	7-1
Troubleshooting Guide . . . . .	7-7
Charge Pressure Test and Adjustment . . . . .	7-11
Hydrostatic Pump Relief Valves . . . . .	7-12
Hydrostatic Pump Removal and Installation . . . . .	7-12
Hydrostatic Pump Drive Coupling Removal and Installation . . . . .	7-14
Drive Motor Removal and Installation . . . . .	7-15

## Hydraulic System

Page 8-1

Introduction . . . . .	8-1
Troubleshooting Guide . . . . .	8-1
Pressure Tests, Control Valve and High-Flow . . . . .	8-17
Tilt Cylinder Test . . . . .	8-19
Self-Leveling Valve Test . . . . .	8-21
Lift Cylinder Test . . . . .	8-22
Solenoid Valve Test - Safety Lock, Brake and Two-Speed . . . . .	8-23
Hydraulic Oil Filter Element Replacement . . . . .	8-25
Tilt Cylinder Removal and Installation . . . . .	8-27
Lift Cylinder Removal and Installation . . . . .	8-29
Lift and Tilt Cylinder Disassembly and Assembly . . . . .	8-32
Gear Pump Removal and Installation . . . . .	8-34
Self-Leveling Valve Removal and Installation . . . . .	8-36
Self-Leveling Valve Adjustment . . . . .	8-38
Safety Lock Valves - Removal and Installation . . . . .	8-39
Lift and Tilt Solenoid Valves - Disassembly and Assembly . . . . .	8-41
Control Valve Removal and Installation . . . . .	8-42
High-Flow Manifold Valve Removal and Installation . . . . .	8-46
High-Flow Manifold Valve Disassembly and Assembly . . . . .	8-47
Pilot Valve Removal and Installation - Hand/Foot . . . . .	8-48
Relief Valve Removal and Installation . . . . .	8-50
Control Valve Disassembly and Assembly . . . . .	8-50
Spool Lock Solenoid Removal and Installation . . . . .	8-51
Hydraulic Tank Removal and Installation . . . . .	8-43
Hydraglide™ Accumulator Removal and Installation . . . . .	8-54
Hydraulic System Schematic, 40 Series . . . . .	8-56



# SPECIFICATIONS

	4640	4840	5640	6640
Make of Engine	Deutz	Deutz	Deutz	Deutz
Model	F3M2011/BF3M2011	F4M2011	F4M2011/BF4M2011	BF4M2011
Fuel	Diesel	Diesel	Diesel	Diesel
Displacement	142 CID (2,3 L)	190 CID (3,1 L)	190 CID (3,1 L)	190 CID (3,1 L)
Horsepower - Net	46/60 hp (34/45 kW) @ 2600 rpm	60 hp (45 kW) @ 2500 rpm	60/82 hp (45/61 kW) @ 2500 rpm	82 hp (61 kW) @ 2500 rpm
Peak Torque	106/140 lb-ft (144/190 N•m) @ 1700/1600 rpm	144 lb-ft (195 N•m) @ 1700 rpm	144/199 lb-ft (195/270 N•m) @ 1700/1600 rpm	199 lb-ft (270 N•m) @ 1600 rpm
Operating Load - SAE*	1500 lbs (680 kg)	1700 lbs (771 kg)	2000 lbs (907 kg)	2400 lbs (1089 kg)
Operating Weight	6200/6250 lbs (2812/2835 kg)	6480 lbs (2939 kg)	7380/7430 lbs (3348/3370 kg)	7800 lbs (3538 kg)
Shipping Weight	5715/5545 lbs (2592/2515 kg)	5825 lbs (2642 kg)	6740/6790 lbs (3057/3080 kg)	7160 lbs (3247 kg)
Hydraulic Reservoir	12 US gal (45 L)	12 US gal (45 L)	16 US gal (61 L)	16 US gal (61 L)
Engine Oil	8.3 US qts (7,9 L)	11.5 US qts (10,8 L)	11.5 US qts (10,8 L)	11.5 US qts (10,8 L)
Fuel Tank	15/17 US gal (56,8/64,4 L)	17 US gal (64,4 L)	19 US gal (71,9 L)	24 US gal (90,9 L)
Hydraulic System Pressure	2750 PSI (190 bar)	2750 PSI (190 bar)	3000 PSI (207 bar)	3000 PSI (207 bar)
Standard Aux. Flow Rate	19 gpm (72 L/min)	19 gpm (72 L/min)	23 gpm (87,1 L/min)	23 gpm (87,1 L/min)
Hi-Flow Aux. Flow Rate	30 gpm (114 L/min)	30 gpm (114 L/min)	36 gpm (136,3 L/min)	36 gpm (136,3 L/min)

Specifications below apply to all 40 Series Models	
<b>Capacities</b>	
Chaincases (each)	8 US qts (7,5 L)
<b>Electrical</b>	
Battery	12-volt DC, 950 CCA
Starter	12-volt DC (2,3 kW)
Alternator	95 A
<b>Hydraulic System</b>	
Travel Speed - Single Speed	0 to 8.4 mph (0 to 13,5 km/h)
Travel Speed - Two-Speed (optional on 4840, 5640, 6640)	0 to 12.5 mph (0 to 20 km/h)

Tire Options	
10 (12) x 16.5 - 8 (10) - ply	High Clearance Flotation tires
10 (12) x 16.5 - 8 (10) - ply	Heavy Duty Poly-filled tires
10 (12) x 16.5 - 8 (12) - ply	Severe Duty tires
10 (12) x 16.5 - 8 (12) - ply	Severe Duty Poly-filled tires
6.50(7.50) x 16 Solid	Solid Rubber tires
33 x 15.50 x 16.5 - 12-ply	Heavy Duty 2000 II tires
14 x 17.5 - 14-ply	High Clearance Flotation tires

Buckets and Capacities			
Width - inches (millimeters)	Bucket Description	Capacity (Heaped)	
65 inches (1651 mm)	Dirt/Construction	10.8 cubic feet	0,31 cubic meters
65 inches (1651 mm)	Dirt/Construction	14.7 cubic feet	0,42 cubic meters
68 inches (1727 mm)	Dirt/Construction	15.3 cubic feet	0,43 cubic meters
68 inches (1727 mm)	Dirt/Construction	19.0 cubic feet	0,54 cubic meters
72 inches (1829 mm)	Dirt/Construction	20.4 cubic feet	0,58 cubic meters
65 inches (1651 mm)	Utility/Snow	18.6 cubic feet	0,53 cubic meters
72 inches (1829 mm)	Utility/Snow	32.5 cubic feet	0,92 cubic meters
15.75, 19.68, 24 inches (400, 500, 610 mm)	Pallet Fork	NA	NA

\*Operating load rated with a 65" inch 4640/4840 (1651 mm) dirt/construction bucket or 68" inch 5640/6640 (1727 mm) dirt/construction bucket in accordance with SAE J818.

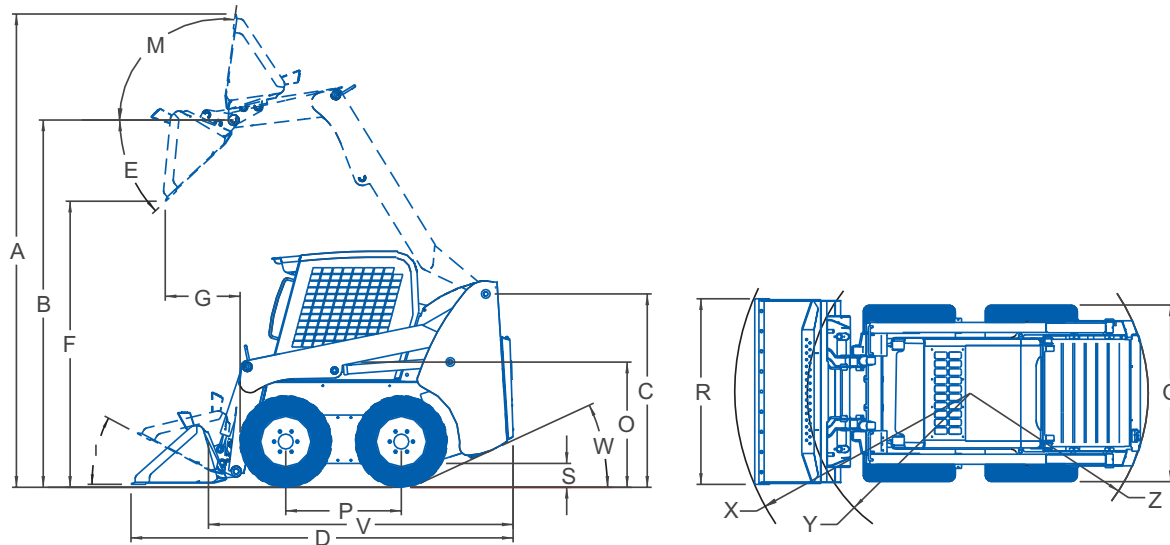

Dimensional Specifications		4640 <sup>1</sup>		4840 <sup>1</sup>		5640 <sup>2</sup>		6640 <sup>2</sup>	
		in.	mm	in.	mm	in.	mm	in.	mm
A	Overall operation height - fully raised	149	3785	149	3785	162	4115	167	4242
B	Height to hinge pin - fully raised	115.5	2934	115.5	2934	123	3124	123	3124
C	Overall height - top of ROPS	78	1981	78	1981	81	2057	81	2057
D	Overall length - bucket down	122.8	3118	126.3	3208	131	3327	141.5	3594
E	Dump angle @ full height	40°		40°		40°		40°	
F	Dump height	89.5	2273	89.5	2273	93.5	2375	91.25	2318
G	Dump reach - bucket (full height)	25	635	25	635	32.8	833	35.5	902
J	Rollback at ground	27°		27°		30°		30°	
M	Rollback angle at full height	86°		86°		84°		84°	
O	Seat-to-ground height	37.5	953	37.5	953	42	1067	42	1067
P	Wheelbase - nominal	37.5	953	41.5	1054	42.5	1080	48.4	1219
Q	Overall width - less bucket	63.5	1613	63.5	1613	67	1702	67	1702
R	Overall bucket width	66	1679	66	1679	70	1778	74	1880
S	Ground clearance to chassis (between wheels)	7.5	191	7.5	191	8.0	203	8.0	203
U	Maximum back grading angle	91°		91°		82°		82°	
V	Overall length (less bucket)	89.8	2291	93.3	2370	95.5	2426	101	2794
W	Departure angle	25°		25°		26°		25°	
X	Clearance circle - front (with bucket)	74.5	1892	76	1930	82	2083	89.5	2273
Y	Clearance circle - front (less bucket)	47	1194	48	1219	50.5	1283	53	1346
Z	Clearance circle - rear	59.5	1511	61.5	1562	66	1676	68	1727

1 - w/ 0.4 cu. yd. bkt., w/ 10 x 16.5 tires  
 2 - w/ 0.56 cu. yd. bkt., w/ 12 x 16.5 tires